



# Spray Flow II



Pressurized and Atmospheric Deaerators

**.005 cc/Liter  
Atmospheric Deaerator**

CONSTANT RECYCLING guarantees deaeration of all dissolved oxygen in excess of .005 cc/liter from 0% to 100% of deaerator capacity.

[industrialsteam.com](http://industrialsteam.com)

# ***Spray Flow II***

## ***Atmospheric .005 cc/liter***

### **When to use**

100% Makeup 0% condensate	Yes
30% Makeup 70% condensate	
High Pressure condensate returns	
100% Turndown	Yes
Load Swings	Yes



### **FEATURES**

#### **CONSTANT RECYCLING**

guarantees deaeration of all dissolved oxygen in excess of .005 cc/liter from 0% to 100% of deaerator capacity.

#### **UNIQUE FULL PARTITION DESIGN**

accepts gravity returns to the atmospheric scrubbing section along with make-up and pumped returns. Deaerating section accepts trapped returns for preferential use of flash steam.

**ELECTRONIC INSTRUMENTATION FOR MODULATING LEVEL CONTROL** includes a HART compatible differential pressure transmitter, PID controller, and motorized control valve.

**SEPARATE DEAERATING & MIXING SECTIONS** offer a two stage continuous cycle which provides .005 cc/l deaerated water during all load conditions regardless of surges from the system.

**ONLY STAINLESS STEEL** components come in contact with undeaerated water.

#### **ATMOSPHERIC NON-CODE VESSEL**

require no annual shutdown for inspection.

#### **CUSTOM ENGINEERED PACKAGED SYSTEM**

includes boiler feedwater pumps and quality components to insure reliable service.

#### **Testing Requirements**

This system requires steady state conditions per the ABMA testing procedure.

## ADVANTAGES

Industrial Steam's exclusive constant recycling feature and the use of a partitioned receiver provide the advantages of a two-tank system as a single package. These advantages are available without the necessity for onsite erection or field installed piping. Expanded deaerating sections are standard for surge condensate loads.

**GUARANTEED PERFORMANCE FROM 0% to 100% of capacity** regardless of load conditions is unmatched by any other deaerator.

**CUSTOM ENGINEERED PACKAGED SYSTEM** results in a small foot print, minimal onsite installation costs, and a single source of responsibility for all major components.

## OPERATION

Modulated make-up water is sprayed through a stainless steel spring loaded nozzle into a stainless steel internal vent condenser located in the scrubbing section. The nozzle produces a thin conical sheet of water which condenses the vapors while permitting oxygen to exit through the unrestricted atmospheric vent. Pumped low temperature returns are also sprayed through the nozzle. Gravity returns flow unrestricted to the scrubbing section.

The combined make-up and returns in the scrubbing section are heated with steam and recycled deaerated water from the deaerating section. Both the steam and deaerated water enter the scrubbing section through separate stainless steel manifolds. The perforated steam manifold provides jets of steam to vigorously scrub the major portion of the dissolved oxygen from the make-up, pumped returns, and gravity returns. The temperature in the scrubbing section is controlled at 210°F (at sea level), which assures the release of the majority of the dissolved oxygen without flash loss.

The scrubbing section water, which is nearly fully deaerated, is continuously recycled to the deaerating section where it is sprayed through stainless steel, wide-angle, full-cone nozzles. Steam enters the deaerating section in response to the temperature in the scrubbing section. Since the cycle is continuous, pure steam is always available for final deaeration. The last traces of oxygen are removed at the point of contact with the purest steam. Excess, fully deaerated water flows continuously from the deaerating section to the scrubbing section through the stainless steel recycle manifold. Trapped returns are piped to the deaerating section where the flash steam is preferentially used for final deaeration.

Since the recycle pump capacity exceeds the deaerator capacity by at least 25%, the deaerator is able to meet .005 cc/l. From zero to 100% load. This same feature also enables the deaerator to supply fully deaerated water to the boiler on start-up. Rapid load changes and on-off boiler feedwater controls, which are very troublesome for other atmospheric deaerators, will not affect the Spray Flow II's performance or operation.

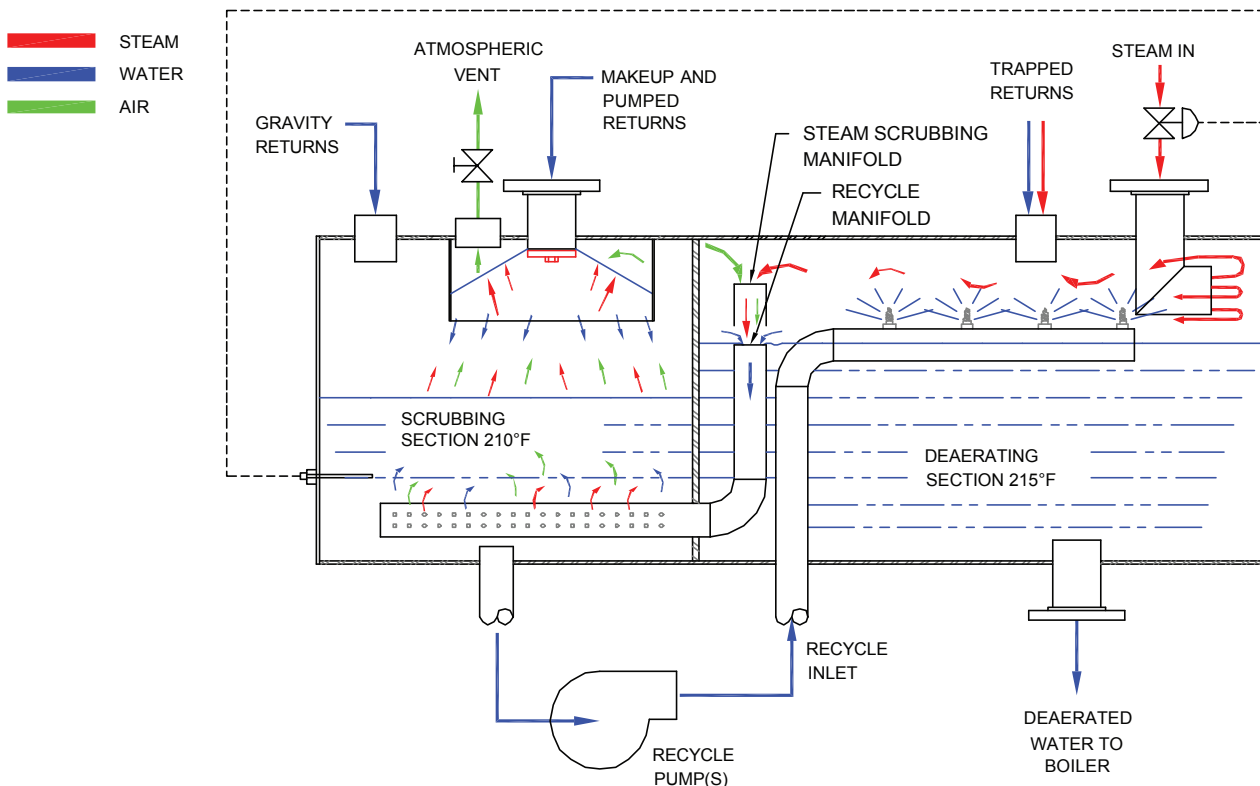

# Components and Sizing

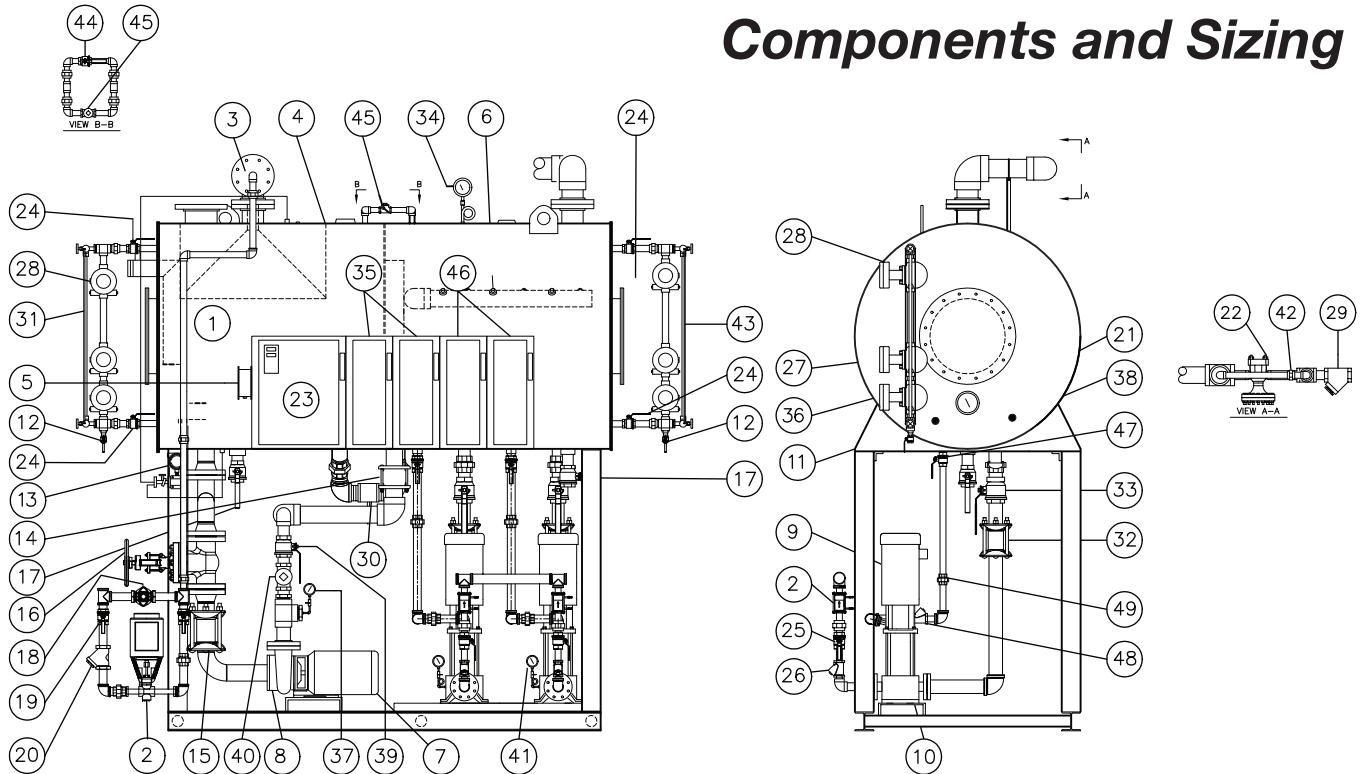

- |                              |                                       |                                       |                                     |
|------------------------------|---------------------------------------|---------------------------------------|-------------------------------------|
| 1 Make-up Controller         | 14 Coupling (Recycle Pump Discharge)  | 26 Check Valve (Discharge)            | 39 Gate Valve (Recycle Discharge)   |
| 2 Make-up Control Valve      | 15 Coupling (Recycle Pump Suction)    | 27 Low Water Alarm                    | 40 Check Valve (Recycle Discharge)  |
| 3 Make-up Nozzle (Stn. Stl.) | 16 Gate Valves (Recycle Pump Suction) | 28 High Water Alarm Switch            | 41 Pressure Gauge (0-300 psi)       |
| 4 Vent Condenser (Stn. Stl.) | 17 Ball Valves (Drain)                | 29 Y-Strainer (Steam Inlet)           | 42 Orifice Union                    |
| 5 Pressure Switch            | 18 Globe Valve (Make-up Inlet)        | 30 Emergency By-pass Valve            | 43 Sight Glass Assembly             |
| 6 Spray Nozzle               | 19 Ball Valves (Make-up Inlet)        | 31 Sight Glass Assembly               | 44 Ball Valve (Vacuum Breaker Line) |
| 7 Recycle Pump Motor         | 20 Y-Strainer (Make-up Inlet)         | 32 Coupling (BF Pump Suction)         | 45 Vacuum Breaker (Check Valve)     |
| 8 Recycle Pump               | 21 Thermometer w/thermowell           | 33 Ball Valve (BF Pump Suction)       | 46 Starter (BF Pump)                |
| 9 Boiler Feed Pump Motor     | 22 Temp Control Valve                 | 34 Pressure Gauge w/cock (0/60in H2O) | 47 Ball Valve (Recirc)              |
| 10 Boiler Feed Pump          | 23 Control Panel (NEMA 1)             | 35 Starter (Recycle Pump)             | 48 Check Valve (Recirc)             |
| 11 Magnesium Anode           | 24 Ball Valve (Column Isolation)      | 36 Low Water Cut Off Switch           | 49 Orifice Union (Recirc)           |
| 12 Ball Valve (Column Drain) | 25 Ball Valve (Discharge)             | 37 Pressure Gauge (0-60 psig)         |                                     |
| 13 Level Transmitter         |                                       | 38 Chemical Feed Quill                |                                     |

MODEL NUMBER	RATED CAPACITY		RECEIVER SIZE D&L INCHES	SYSTEM CAP. TO OVERFLOW		RECYCLE PUMP		APPROX OVERALL DIMENSIONS			APPROX SHIPPING WEIGHT **
	LBS/HR	HP		GALS	MIN.	GPM	HP	HEIGHT*	L	W	
1SP5I I	3,450	100	30 x 72	220	31.8	10	3/4	90	84	42	1,600
2SP5I I	6,900	200	30 x 96	290	21	20	3/4	90	108	42	1,800
3SP5I I	10,350	300	36 x 96	424	20.2	30	3/4	96	108	48	2,000
4SP5I I	13,800	400	36 x 96	424	15.3	40	3/4	96	108	48	2,000
5SP5I I	17,250	500	42 x 96	576	16.7	45	3	102	108	54	2,620
6SP5I I	20,700	600	42 x 96	576	13.9	50	3	102	108	54	2,620
7SP5I I	24,150	700	48 x 96	750	15.5	70	3	106	108	60	3,270
8SP5I I	27,600	800	48 x 96	750	13.6	80	3	106	108	60	3,270
10SP5I I	34,500	1000	54 x 96	900	12.9	90	3	110	108	66	4,010
12SP5I I	41,400	1200	54 x 120	1130	13.4	100	3	110	144	66	4,330
15SP5I I	51,750	1500	60 x 120	1390	13.2	135	3	116	144	72	5,275
18SP5I I	62,100	1800	60 x 144	1660	13	170	5	116	156	72	5,300
21SP5I I	72,450	2100	66 x 144	1900	13.5	185	5	124	156	78	6,770
24SP5I I	82,800	2400	66 x 168	2320	13.8	200	5	124	156	78	6,900
30SP5I I	100,000	3000	66 x 192	2650	12.6	275	7 1/2	124	204	78	7,540
36SP5I I	125,000	3600	72 x 192	3210	12.7	315	7 1/2	130	204	84	9,300

Consult factory for systems above 300,000#/hr \* Overall height includes 48" stand. \*\* Shipping weight does not include boiler feed pumps or any optional equipment

- Consult Factory for systems over 300,000 lbs./hr. - Weights do not include pumps or optional equipment \* Includes 48" Stand \*\* Includes Control Panel

## ***Additional Industrial Products***



**High Efficiency  
Boilers**

L.E.S Boilers, LLC  
Horizontal Boilers  
Vertical Boilers  
[www.lesboilers.com](http://www.lesboilers.com)



**INDUSTRIAL  
FUEL SYSTEMS, LLC**  
*Mission Critical Fuel Oil Systems*

Industrial Fuel Systems, LLC  
Mission Critical Fuel Oil Systems  
Pump Sets  
[www.ifuelsys.com](http://www.ifuelsys.com)



**atlantic**  
feedwater systems  
*"Specialists in Boiler Feedwater Equipment"*

Atlantic Feedwater Systems, Inc  
Boiler Feed Systems  
Feedwater Steam  
[www.boilerfeedsystems.com](http://www.boilerfeedsystems.com)

**W I L S O N**  
A graphic consisting of five green triangles of varying heights and widths, arranged in a row.  
**ENGINEERING**

Wilson Engineering  
Boiler Blowdown Systems  
Blowdown Heat Recovery  
[www.wilsonblowdown.com](http://www.wilsonblowdown.com)

---

Have questions or need help specifying this equipment? Email: [engineering@industrialsteam.com](mailto:engineering@industrialsteam.com)

Need help with an existing system or parts? Email: [techsupport@industrialsteam.com](mailto:techsupport@industrialsteam.com)

Looking for a local representative? Email: [sales@industrialsteam.com](mailto:sales@industrialsteam.com)

Literature available for download at [industrialsteam.com](http://industrialsteam.com)

---



Pressurized and Atmospheric Deaerators

**Industrial Steam**

1403 SW 7th Street, Atlantic, Iowa 50022  
TEL (712) 243-5300 FAX (712) 243-3440

[industrialsteam.com](http://industrialsteam.com)